

AS7D99CH

STANDARD MATERIALS AND CONSTRUCTION

FRAME: .081" thk. (nominal) extruded aluminum, 6063-T52/T6 alloy.

BLADE: .081" thk. (nominal) extruded aluminum, 6063-T52/T6 alloy.
Horizontal drain blades approximately 3" on center, vertical blades approximately 1 3/16" on center.

LOUVER FACE: Head and blades are contained within jambs, sill contains jambs.

SCREENS: (When indicated, in a removable frame.)

1/2" flattened aluminum (.051" thick),

-or- 1/2" sq. mesh, intermediate double-crimped aluminum wire, .063" dia.,

-or- 18/16 mesh, .011" dia. aluminum wire, insect screen.

DRAIN PAN: .060" thk. (nominal) formed aluminum with welded and caulked end dams.

FINISH: Mill

OPTIONS

Finish - Baked Enamel, Kynar, Anodized

NOTES

1. Nominal deductions will be made to the opening size given.
2. Louvers larger than the maximum factory assembled size will require field assembly of smaller louver sections.
3. Approximate shipping weight is 10.5 lbs./sq.ft.

LOUVER SIZES

Min Panel	Max Single Panel
12"W x 12"H	60"W x 96"H (30) sq. ft.

This louvers has been tested to **AMCA Standard 550 for High Velocity Rain Resistance**. See Page 2 for seal and listing information.

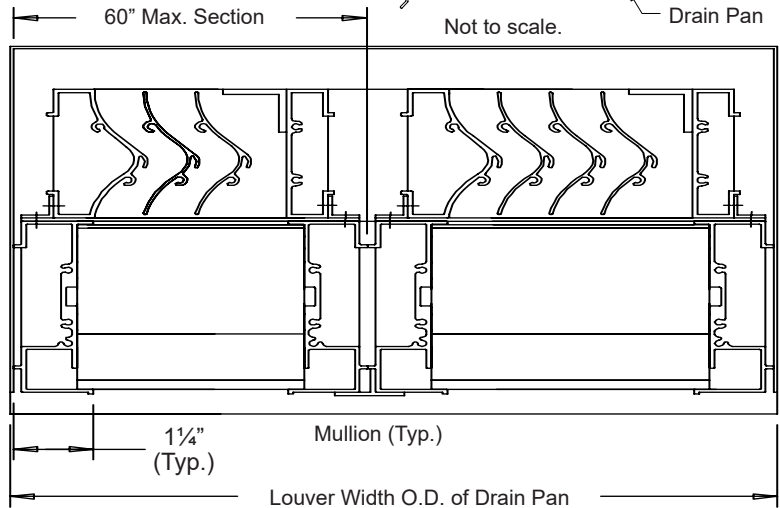
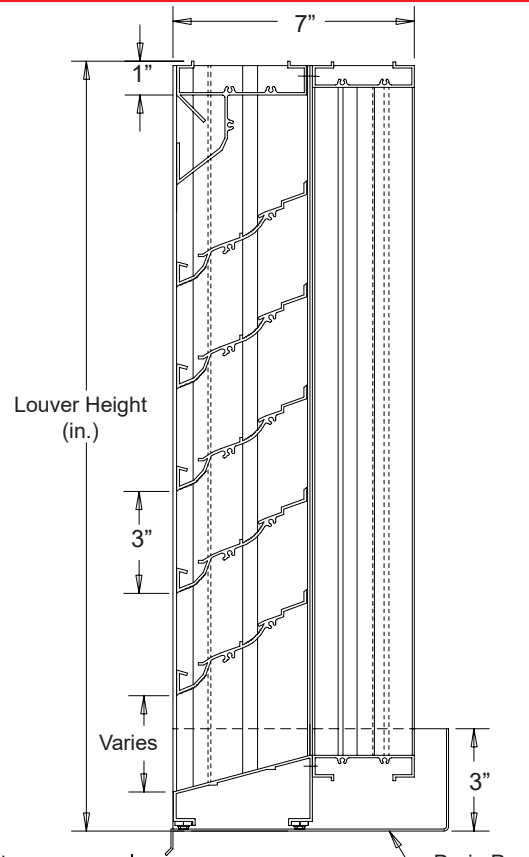
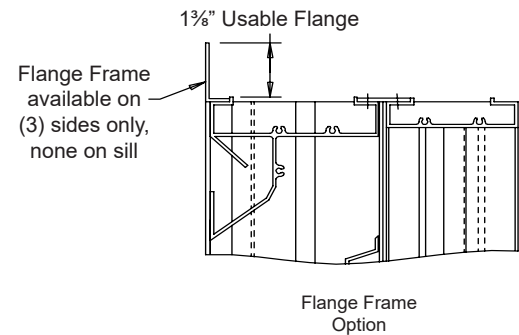

Nominal Deductions will be made to the opening size given.

In the interest of product development, Airline Louvers reserves the right to make changes without notice.

Item #	Qty	Width	Height	Width	Height	Mullion	Type	Location	Union Made
		Opening Size		Louver Size			Screens		
Arch. / Eng. :						EDR:	ECN:	Job:	
Contractor:						Date:	DWN:	DWG:	
Project:									



AS7D99CH

PERFORMANCE DATA

Pressure Drop: .022 in. wg at 398 fpm

Free Area: 6.78 sq.ft. (42.4%) for 48"W x 48"H sample tested in accordance with AMCA Standard 500-L.

Beginning Point of Water Penetration: Greater than 1250 fpm

Class "A" Rating with 100% efficiency at 3 in. rain fall at intake velocity of 1559 fpm (10,571 cfm) at wind speed of 29 mph.

Class "A" Rating with 100% efficiency at 8 in. rain fall at intake velocity of 1568 fpm (10,634 cfm) at wind speed of 50 mph.

Testing based on 48" x 48" based on AMCA Standard 500-L.

Ratings do not include effects of a screen.

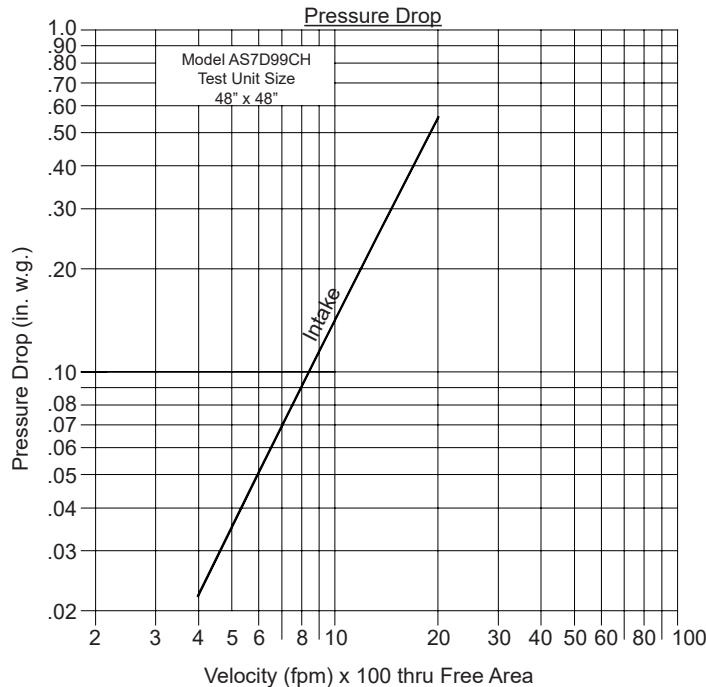

Intake air converted to standard air density.
Tested to AMCA Standard 500-L, Figure 5.5.

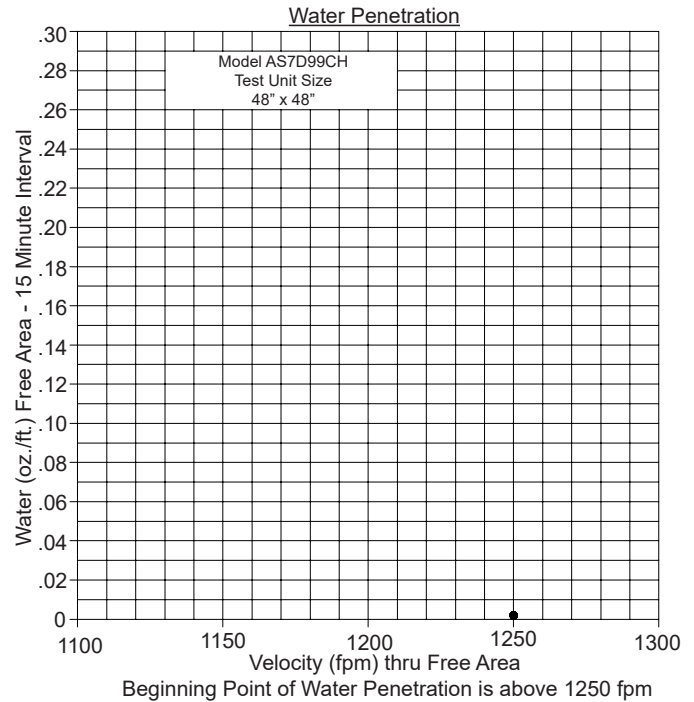

Free Area (sq.ft.)

		Width (in.)								
		12"	18"	24"	30"	36"	42"	48"	54"	60"
Height (in.)	12"	.26	.44	.62	.79	.97	1.15	1.32	1.50	1.68
	24"	.62	1.03	1.45	1.86	2.27	2.69	3.10	3.51	3.93
	36"	.99	1.64	2.30	2.96	3.61	4.27	4.93	5.59	6.24
	48"	1.36	2.26	3.17	4.07	4.98	5.88	6.78	7.69	8.59
	60"	1.71	2.85	3.99	5.14	6.28	7.42	8.56	9.70	10.84
	72"	2.07	3.45	4.82	6.20	7.58	8.96	10.34	11.71	13.09
	84"	2.42	4.04	5.65	7.27	8.88	10.50	12.11	13.73	15.34
96"	2.80	4.67	6.54	8.41	10.28	12.15	14.02	15.89	17.76	



HIGH VELOCITY
RAIN RESISTANT
WITH BLADES FULLY OPEN

See www.AMCA.org for all certified or listed products

Airline Louvers certifies that the Model AS7D99CH shown herein is approved to bear the AMCA Listing Label. The ratings shown are based on tests and procedures performed in accordance with AMCA Publications and comply with the requirements of the AMCA Listing Label Program.

The AMCA Listing Label applies to High Velocity Rain Resistant Louvers.

This label does not signify AMCA performance certification.

AS7D99CH

Wind Driven Rainwater Penetration Test
Conducted to AMCA Standard 500-L.

Test size 1m x 1m (39.7" x 39.7") core area, 43.25" x 45.375" nominal.
Louver Free Area 6.78 square feet.

Core Ventilation (m/s)	0.0	0.5	1.0	1.5	2.0	2.5	3.0	3.5	4.0	4.5	5.0	Rain Fall / MPH
FPM	-	-	-	-	-	-	-	-	-	-	982	3 in. / hr. rain fall and 29 mph Velocity
Free Area Ventilation (cfm)	-	-	-	-	-	-	-	-	-	-	10,571	
Free Area Velocity (fpm)	-	-	-	-	-	-	-	-	-	-	1,559	
Effective Rating Class	A	A	A	A	A	A	A	A	A	A	A	
Effectiveness Ratio (%)	-	-	-	-	-	-	-	-	-	-	100	
FPM	-	-	-	-	-	-	-	-	-	-	988	8 in. / hr. rain fall and 50 mph Velocity
Free Area Ventilation (cfm)	-	-	-	-	-	-	-	-	-	-	10,634	
Free Area Velocity (fpm)	-	-	-	-	-	-	-	-	-	-	1,568	
Effective Rating Class	A	A	A	A	A	A	A	A	A	A	A	
Effectiveness Ratio (%)	-	-	-	-	-	-	-	-	-	-	100	

Wind Driven Rain Penetration Classifications

Class	Effectiveness %
A	100 to 99%
B	98.9% to 95%
C	94.9% to 80%
D	Below 80%

Discharge Loss Coefficient Classifications

Class	Discharge Loss Coefficient
1	0.4 and above
2	0.3 to 0.399
3	0.2 to 0.299
4	0.199 and below

Discharge Coefficient

Intake Cd= .33 (CLASS 2)

Class 1 Loss Coefficient has the least resistance to airflow.

1. Core area is the front opening of a louver assembly with the blades removed.
2. Core area velocity is the airflow rate through the louver divided by the core area (39.37" x 39.37").
3. Free area is the minimum area through which air can pass. It is determined by multiplying the sum of the minimum distance between intermediate blades, top blade and head, bottom blade and sill, by the minimum distance between jambs.
4. Discharge loss coefficient is calculated by dividing a louver actual airflow rate vs. a theoretical airflow for the opening, providing an indication of the louver air flow characteristics.



Airline Louvers certifies that the Model AS7D99CH shown herein is licensed to bear the AMCA Seal. The ratings shown are based on tests and procedures performed in accordance with AMCA Publication 511 and comply with the requirements of the AMCA Certified Ratings Program. The AMCA Certified Ratings Seal applies to Air Performance, Water Penetration, and Wind Driven Rain only.